

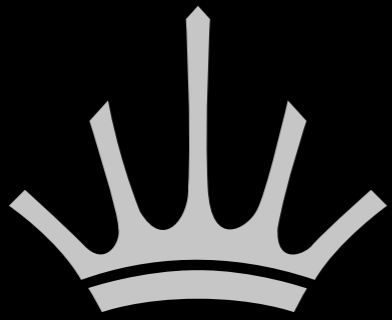

GRINDING UNLIMITED

E80S





T H E K I N G O F G R I N D E R S



M A H L K Ö N I G

GRINDING INNOVATIONS

FUELED BY A PASSION FOR WORLD CLASS COFFEE.

Our mission at Mahlkönig is to support passionate coffee enthusiasts and professionals with innovative grinding solutions to raise coffee enjoyment to the next level. For several generations, we have been combining our valuable brand heritage with top-level engineering and our understanding of market requirements to shape the trends of tomorrow.

We are driven by our motivation to develop the latest technology, tailored to individual needs for optimal workflow at every coffee bar. We work to the highest quality standards, leaving nothing to a chance. Therefore, we rely exclusively on in-house engineering and production, especially when it comes to the burrs, the heart of the grinder. Engineered for outstanding performance, durability and reliability, all Mahlkönig products deliver the maximum value in use.

As "The King of Grinders" we are passionate about pioneering the world of grinding alongside our customer's requirements. Our superb premium grinders combine the latest high-tech innovations with state-of-the-art engineering and design. They are manufactured to ensure excellent accuracy, perfect quality in the cup and the greatest achievable taste, creating the ultimate experience in coffee enjoyment.

E80S

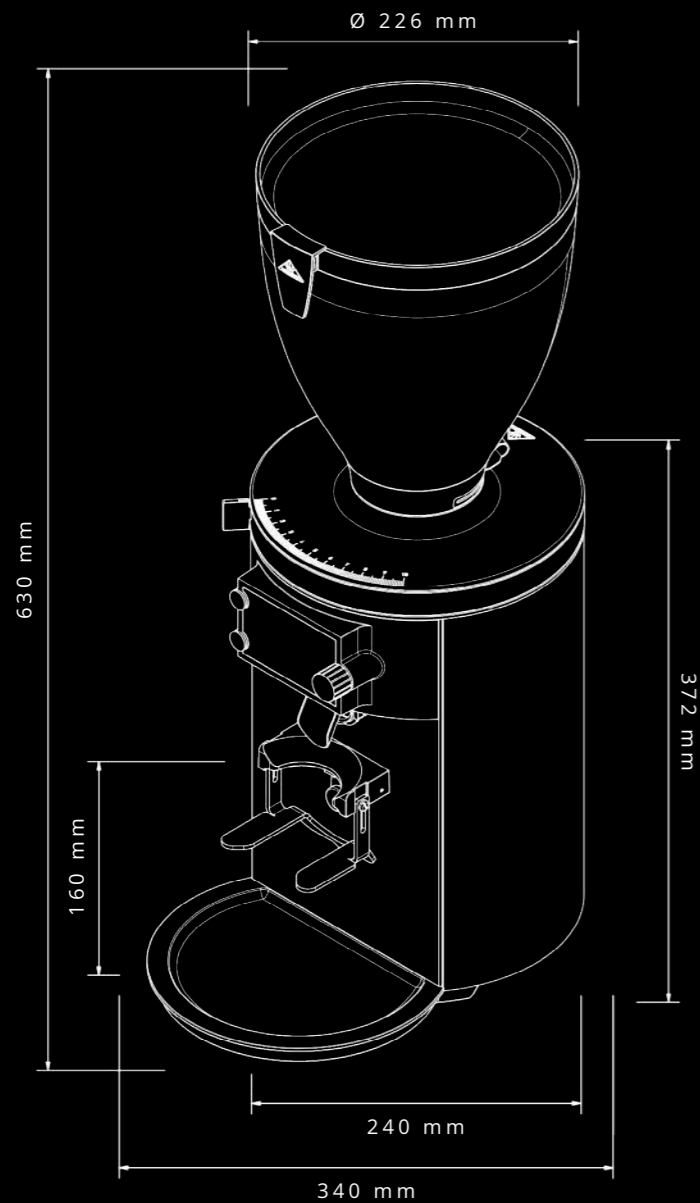

- modern elegant design
- indestructible bean hopper
- quick and easy grind adjustment
- high-definition 88.3 mm display
- intuitive user interface
- Disc Distance Detection
- top-notch grinding profile
- supersized 80 mm special steel burrs
- high performance motor
- innovative temperature control
- near-silent grinding
- adjustable and removable spout
- comfortable cleaning and maintenance concept

KEY FEATURES





*"Creating a perfect espresso grinding profile for an optimal extraction – **even under high workloads** – that's what any leader in specialty coffee is actually looking for. The E80S with its 80 mm special steels burrs is the best choice for espresso grinding without limits. Its burr size, material and geometry make all the difference."*

STEFANOS DOMATIOTIS

World Brewers Cup Champion, certified trainer of the Specialty Coffee Association and a judge at many international competitions



FASTEST GRINDER IN ITS CLASS

Setting the new benchmark in premium espresso grinding.

Coffee shops and individual baristas need high-quality, reproducible and accurate grinding results. Mahlkönig's E80S is the fastest and most advanced premium espresso grinder of its class on the market. It simply amazes with its high-capacity, precise dosing and fast grinding abilities – without compromising on consistency or taste. The powerful motor has an active temperature control ensuring a high daily output, while providing uniformity in all taste parameters - especially important in heavy-duty environments.

The E80S is a high-performing, durable espresso grinder equipped with unique 80 mm steel burrs and the pioneering Disc Distance Detection (DDD) technology.



High capacity and great taste.

When it comes to “quantity vs. quality”, demanding shop owners had a hard decision to make. Thanks to the efficient motor and oversized burrs of the E80S, there is no need to make compromises anymore. Now, you can have both! Break the boundaries and explore new possibilities with unlimited espresso grinding.

6 Double shots per minute.

Mahlkönig's engineering team has equipped the motor of the E80S with a ground-breaking temperature control. The smart construction is designed to create an airflow taking in fresh air that cools down the motor continuously. An additional fan gets activated when the E80S is grinding higher loads, in order to prevent your espresso beans from suffering from any possible negative influence by rising temperatures.

Even under heavy-duty laboratory tests, where the E80S was used to grind 600 shots straight, the temperature of the ground coffee never reached the 50-degree mark.

The motor is designed to handle high workloads:

Max. nominal power	ON/OFF	Duty Cycle (DC)	Performance (DS*2 = 20 g)
220-240 V 50/60 Hz	3 s ON / 3 s OFF	50 % ZK S3*1 (6 s)	6 DS*2/min
110-127 V 60 Hz	3 s ON / 3 s OFF	50 % ZK S3*1 (6 s)	6 DS*2/min
100 V 50/60 Hz	3 s ON / 3 s OFF	50 % ZK S3*1 (6 s)	6 DS*2/min

*1 S3: Intermittent periodic duty
*2 DS: Double shot



M A D E I N G E R M A N Y

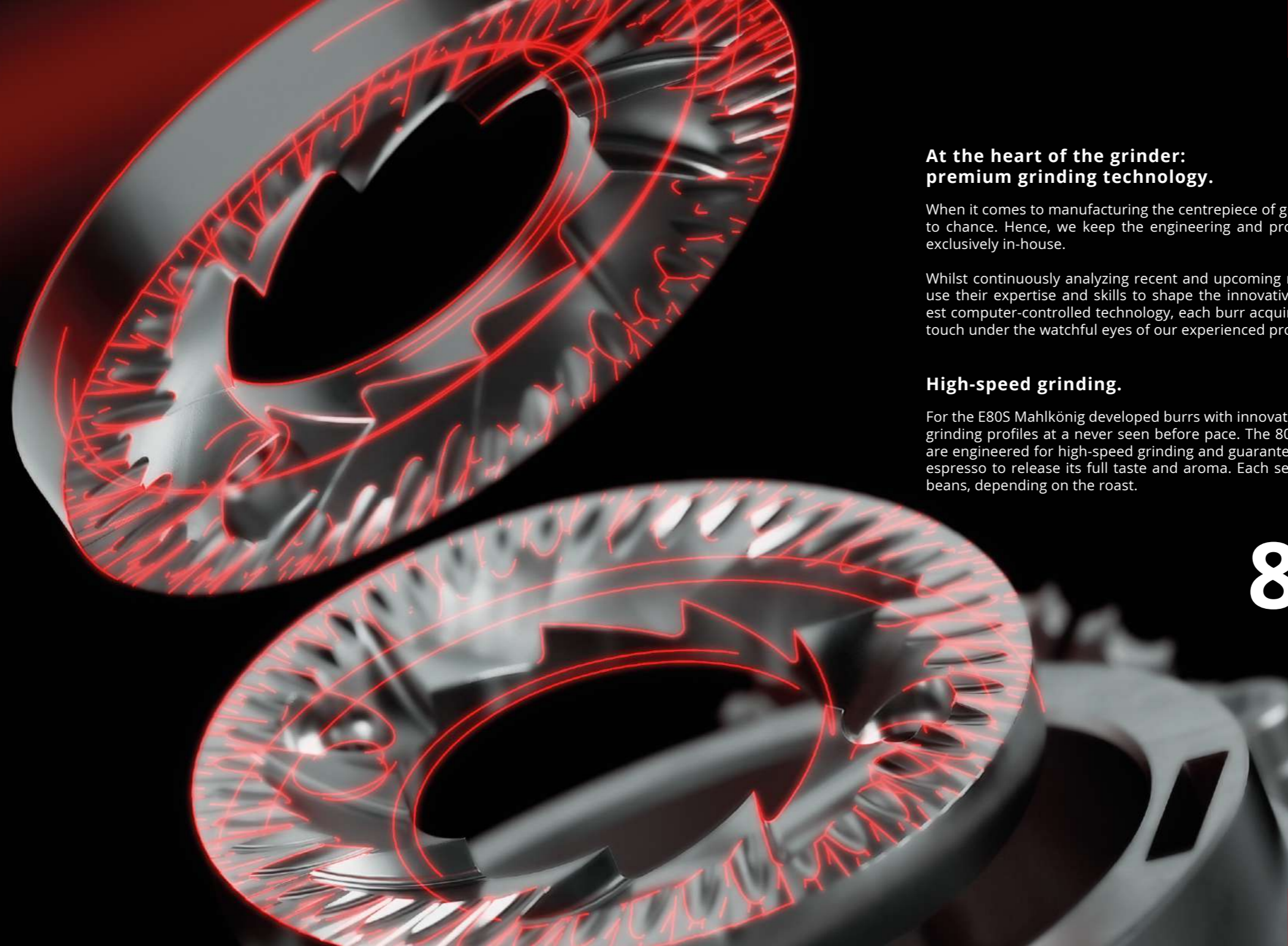

**At the heart of the grinder:
premium grinding technology.**

When it comes to manufacturing the centrepiece of grinding technology, we leave nothing to chance. Hence, we keep the engineering and production departments for our burrs exclusively in-house.

Whilst continuously analyzing recent and upcoming market requirements, our engineers use their expertise and skills to shape the innovative spirit of Mahlkönig. Using the latest computer-controlled technology, each burr acquires its individual shape and finishing touch under the watchful eyes of our experienced production team in Hamburg.

High-speed grinding.

For the E80S Mahlkönig developed burrs with innovative geometry that features top-notch grinding profiles at a never seen before pace. The 80 mm special steel burrs of the E80S are engineered for high-speed grinding and guarantee optimal particle sizes, allowing the espresso to release its full taste and aroma. Each set of burrs lasts for up to 2000 kg of beans, depending on the roast.

80 mm



Precise grind adjustment.

The innovative Disc Distance Detection (DDD) function lets you set the degree of fineness with the utmost precision and perfection.

The E80S is one of first espresso grinders to feature grind adjustments based on the actual distance between the burrs. The indication allows a precision of 0.001 mm. Keeping the perfect individual grinder settings for your espresso has never been so easy, yet so precise.



Pioneering grind-adjustment technology lets you set and keep the perfect degree of fineness.

The ultrafine thread inside the grind-adjustment mechanism of the E80S enables the utmost precision when it comes to obtaining the right degree of fineness for your espresso beans. The adjustment range spans 150 to 450 µm, whilst the 100 step indicating scale offers meticulous repeatability. An auto-lock system keeps the adjustment in place. However, to ensure the setting doesn't get changed unintentionally, there an additional dial on the back of the grinder to lock the perfect degree of fineness if required.

Our revolutionary spout, designed for perfectly-centered espresso grinding.

The re-designed spout adapts to every portafilter within seconds by being simply pushed or pulled into place. Made from specially selected anti-static material, honed into a uniquely effective shape, it allows the grounds to flow very fluffy into the portafilter.



Grinding has never sounded so good.

We all want our customers to fully enjoy espresso without disturbance. With this in mind, a team of Mahlkönig engineers and acoustics experts developed the body of the E80S with a strong focus on noise reduction and frequency optimization. The sturdy grinder housing, foam-insulated side covers and a special foil behind the front cover, all help to reduce and deepen the grinding sound to below 70 dB(A).



Optimal operation.

The E80S is equipped with a premium 88.3 mm color display, providing the highest visual comfort when setting your grinder or when checking statistics and service intervals.

Intuitive use on the next level.

The control functions of the E80S enable rapid navigation through the menu. The innovative software is based on state-of-the-art technology and features modern user-friendly icons. You can set your preferred recipe within seconds and be ready to grind.



Style up your espresso bar!

The E80S with its modern and clean look shines like a star on your spacious counter, demonstrating first-class grinding quality and elegant design. It is the perfect fit for a top-notch espresso bar setup, both performance-wise and visually.

Choose either all matte black panels or the white side panels to sit on the polished aluminum body and make your bar's style complete.

Polished aluminum, matte black

Polished aluminum, matte black & white



Absolutely indestructible: the bean hopper

The new ultra-robust bean hopper of the E80S is practically unbreakable. Relying on screws instead of adhesive, the bean hopper and adapter will never come apart during use and the integrated finger protection inside the bean hopper guarantees user safety. Simply fill it with up to approx. 1800 g of beans and start grinding. If required, two optional sizes of bean hopper are available - the smaller approx. 250 g unit or the medium approx. 1200 g version. The standard 1800 g hopper features our new smart clip on the lid that can be used to hold a note - for example, an information card for the customer to learn more about the coffee or brewing/recipe instructions to be kept in mind by the barista.

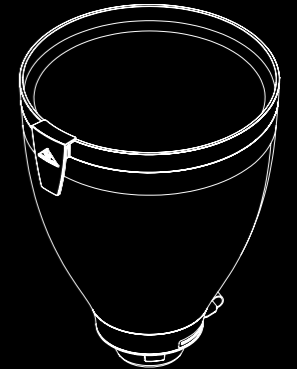

Perfectly adaptable: the portafilter holder

The rock steady portafilter holder is incredibly simple to adjust by loosening and tightening just two screws, allowing it to fit any portafilter with ease. Its sturdy stainless steel construction will neither bend nor bow. This, along with the robust start-stop button, guarantee trouble-free use, even during the busiest of rush hours.

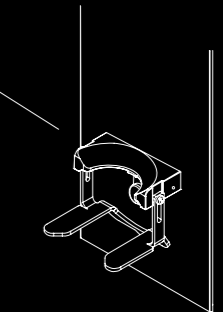

Clean bar counter: the drip tray

The drip tray with its optimal size, shape and position help to keep your bar clean and free from unwanted grounds. Held in place by two strong magnets it self-adjusts and easily slips into position, making it simple to detach, clean and put back into place.

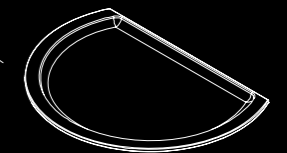

TECHNICAL DETAILS

Voltage // frequencies // phases // nominal power	220-240 V // 50/60 Hz // 1~ // 520/600 W 110-127 V // 60 Hz // 1~ // 845 W 100 V // 50/60 Hz // 1~ // 620/780 W
Idle speed	1400 rpm (50 Hz) 1700 rpm (60 Hz)
Burr diameter	80 mm
Burr material	Special steel
Average grinding capacity*	50 Hz: 6-7 g/s @ 250 µm 60 Hz: 7-8 g/s @ 250 µm
Bean hopper capacity	approx. 1800 g
Dimensions (w x h x d)	24 x 63 x 34 cm
Dimensions of packing (w x h x d)	69.7 x 28.7 x 47.5 cm
Net weight	17.6 kg
Gross weight	19.4 kg
Certifications	CE, CB, ETL Safety, ETL Sanitation
Standards	Conforms to IEC/EN 60335-1 IEC/EN 60335-2-64 Certified to UL 763 CSA C22.2 No. 195 NSF/ANSI 8
Standard colors	Polished aluminum, matte black Polished aluminum, matte black & white
Special equipment (bean hopper)	approx. 250 g or approx. 1200 g

*Depends on the grinding goods and the chosen degree of fineness. | All measured values under laboratory conditions.
Other electric specifications available on request. | Subject to change without prior notice.



**CAFFEINE
LIMITED**
Quality, Pride & Passion

CAFFEINE LIMITED
3 LITTLE MUNDELLS, WELWYN GARDEN CITY
HERTFORDSHIRE, UNITED KINGDOM, AL7 1EW
T. 01707 278 400 W. www.caffeinelimited.com



www.mahlkoenig.com | www.hemrogroup.com